



HNRRKIT

Hangar Networked Re-Radiating Kit

Technical Product Data



Please Note that the pictured L1-RAMB antenna mount is not included in the HNRRKIT.

Features

- **Amplified Roof Antenna**
Gain \geq 35dB
- **Re-Radiating Amplifier with Power Supply**
Typical Gain 30dB
- **Optional Mounting Kit Hardware**
Roof Antenna Mount & Adjustable Re-Radiating Mount
- **Variable Gain Option with LCD Display**
Push Button Control in 1dB Increments 0-30dB gain

Description

The GPS Hanger Re-Radiating Kit (HNRRKIT) is a complete re-radiating system that allows re-radiation of the GPS L1 signal indoors. The HNRRKIT consists of an active roof antenna, a re-radiating amplifier with a wall mount plug-in transformer that powers the entire system, and a passive re-radiating antenna. The GPS L1 signal from the roof antenna is amplified and radiated indoors. Thus, if a receiver has line of sight with the re-radiating antenna, it can receive the GPS signal indoors up to 100 feet. A cable from the roof antenna to the re-radiating kit is required and can be purchased separately.

Roof Antenna Specifications, $T_A = 25^{\circ}\text{C}$

Parameter	Conditions	Min	Typ	Max	Units
Frequency	L1		1.575		GHz
Bandwidth			20		MHz
Out Imped. ⁽¹⁾			50		Ω
Pre-Amp Gain			35	38	dB
Noise Figure			2.75		dB
Output SWR				2.0:1	-
Filtering	1626 MHz	-20			dB
	1500 MHz	-10			dB
Req. DC Input V.		4.5		5.5	Vdc
Current			22		mA

RF Connector Options		
Connector Options	CONNECTOR STYLE	CHARGE
	Type N-female	NC

Re-Radiating Amplifier Electrical Specifications, $T_A = 25^{\circ}\text{C}$

Parameter	Conditions	Min	Typ	Max	Units
Freq. Range	Ant – J1	1.1		1.7	GHz
In/Out Imped.	Ant, J1		50		Ω
Gain ⁽¹⁾					dB
		29	30	31	dB
Input SWR ⁽²⁾	J1 - 50 Ω			1.8:1	-
Output SWR	Ant - 50 Ω			1.8:1	-
Noise Figure	Ant – J1		3.3	3.5	dB
Current				20	mA
Gain Flatness	L1 – L2 ; Ant – J1		0.5	1	dB
Reverse Isolation	J1 – Ant	35			dB
Group delay Flatness	$\tau_{d,max} - \tau_{d,min}$; Ant – J1			1	ns

Re-Radiating Amp System Power Supply Options		
Source Voltage Options	VOLTAGE INPUT	STYLE
	110VAC	Transformer (Wall Mount)
	220 VAC	Transformer (Wall Mount)
	240 VAC (United Kingdom)	Transformer (Wall Mount)
	Customer Supplied DC 9-32 VDC	Military Style Connector
Re-Radiating Amp Gain Control Options		
Standard Gain	30 dB (Custom Gain between 0-30dB available upon request)	
Variable Gain	$-3 \leq \text{Gain} \leq 25$ dB	
Variable Gain with LCD Display	0-30dB gain range with push button control in 1dB increments	

Re-Radiating Antenna Electrical Specifications, $T_A = 25^{\circ}\text{C}$

Parameter	Conditions	Min	Typ	Max	Units
Frequency	L1		1.575		GHz
Bandwidth				20	MHz
Impedance			50		Ω
Peak Gain			3		dBic
Output SWR				1.5:1	-
Polarization			RHCP		-

Part Number Configuration

HS E W VG HNRRKIT N / 5 / 110

Options:

HS = Hermetically Sealed

E = EMI Shielding

W = Weatherproofing

Re-Radiating Kit Type:

VG = Variable Gain knob control 0-23dB gain

VGLCD = Variable Gain with push button control in 1dB increments 0-30dB gain

HNRRKIT = L1 Hangar Networked Re-Radiating Kit

Connector Options (Type N-female Standard):

N = N-type, **S** = SMA, **T** = TNC, **B** = BNC

DC Output Voltage

5 = Amplifier Output Voltage (included antenna requires 4.5-5.5 vdc--5vdc is default voltage)

Source Voltage (Power Supply Options)

110=110VAC, **220**=220VAC (2 prong Euro), **240**=240 (3 prong UK)

MC = Military DC Connector (User Supplies 9-32VDC)

(Military DC Mating Connector is included standard with the MC power option)

Contact GPS Networking Technical Support at 719-595-9880 or salestech@gpsnetworking.com for any questions regarding non-standard configurations and corresponding part numbers)

Performance:

NRRKAMP (Re-Radiating Kit Amp Standard Gain)

Input SWR (Ant. Port) and Frequency Response: Ant. To J1) (Typical, type N connectors):

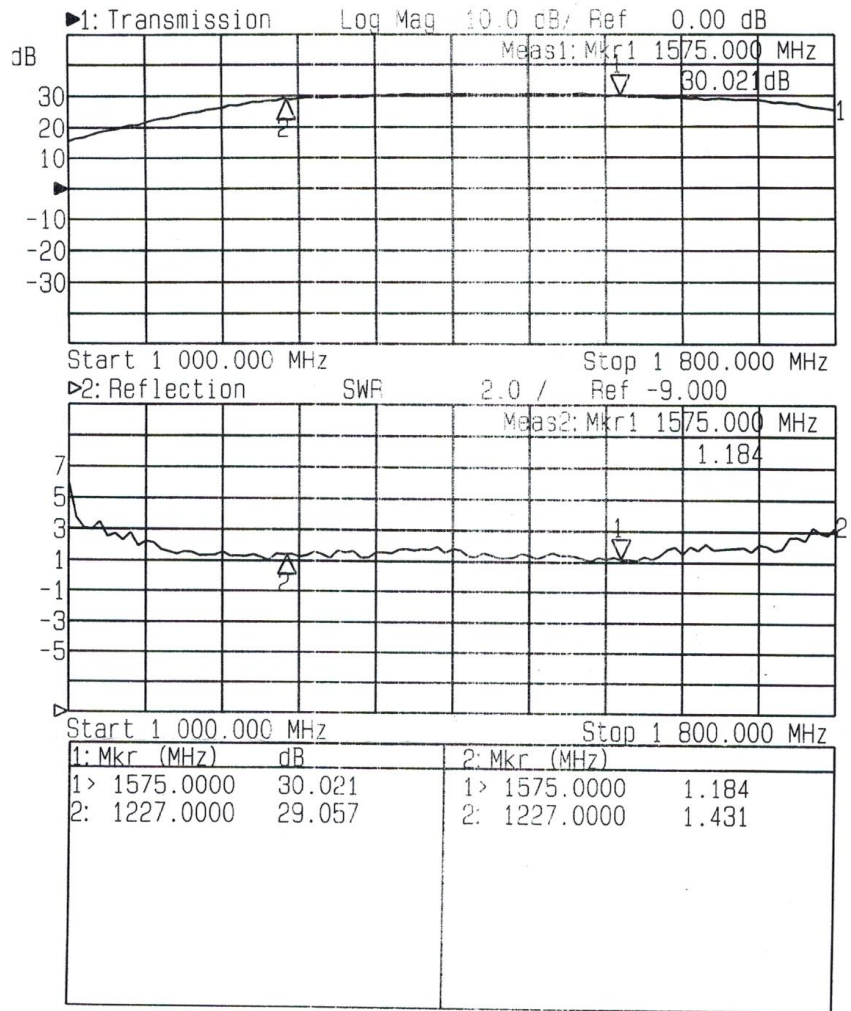

Performance:

L1GPSA (L1 Active Antenna-Outdoor)

Immunity to noise and interference

Secure performance by attenuating noise and interference near GPS L1 frequency through triple filtering design

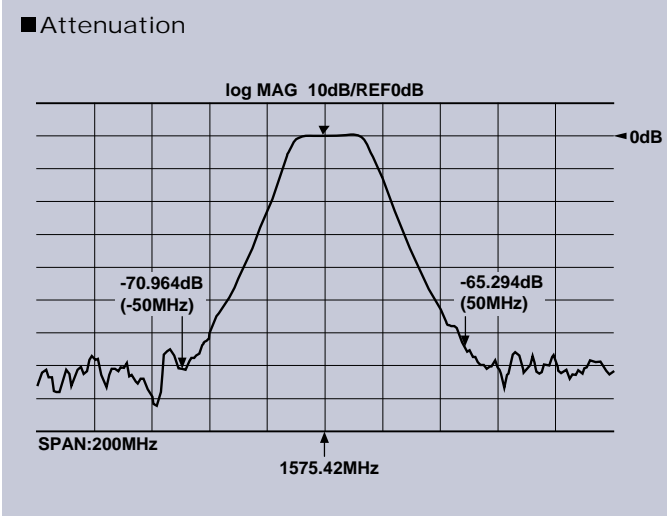

Immunity to lightning surge

Model with enhanced immunity to lightning surge [IEC61000-4-5 Level 4 (4000V)] preventing antenna failure caused by induced lightning

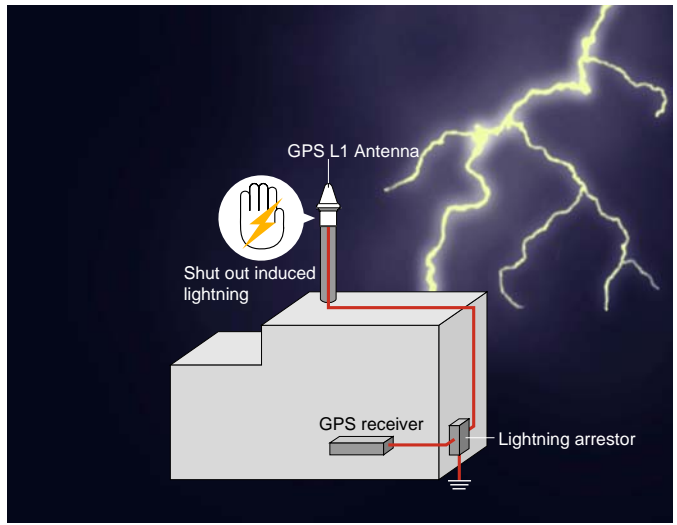

GPS ANTENNA SPECIFICATIONS

RoHS Compliant

Model No.: PA175S

Antenna:	
Center Frequency	1575 ± 3 MHz
VSWR	1.5:1 max.
Bandwidth	20MHz min. at -10dB
Impedance	50Ω
Axial Ratio	3dB max. θ=0°
Peak Gain	4dBic min.
Ground Plane	70 mm x 70mm
Gain Coverage	≥ -4dBic at -90° ≤ θ ≤ 90° (over 75% volume)
Power Handling	1 watt
Polarization	RHCP
Mechanical:	
Weight	48g max.
Size	66 x 66 x 18 mm
Connector	SMA jack
Environmental:	
Working Temperature	-40°C < T < +85°C
Storage Temperature	-50°C < T < +95°C
Vibration	Sine Sweep, 1G(0-P), 10-150-10Hz each axis
Humidity	95%~100% RH

Note: Specifications subject to change without notice.

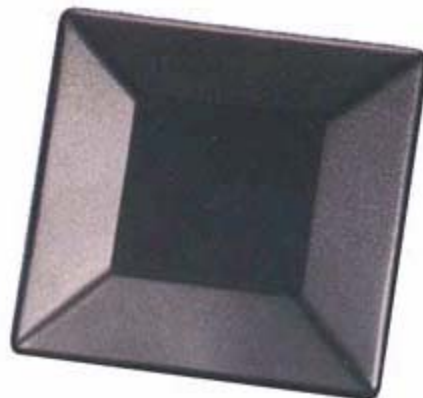

Mechanical **and Environmental**

Active Antenna (Outdoor)

Dimensions (Unit:mm)

Mounting: Pipe/Pole Mount included (optional pipe/base mount available)

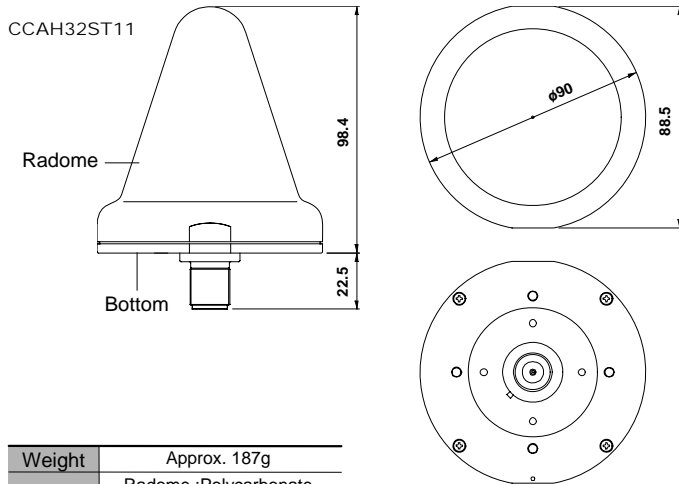

Weight	Approx. 187g
Material	Radome :Polycarbonate Bottom :Die-cast aluminum

Temperature: -40C to + 85C

Humidity: 40-95% RH (below Dew Point)